

## Description

The DC0511S5 is a 2-line bi-directional TVS diode, utilizing leading monolithic silicon technology to provide fast response time and low ESD clamping voltage, making this device an ideal solution for protecting voltage sensitive high-speed data lines. The DC0511S2 complies with the IEC 61000-4-2(ESD) standard with  $\pm 30\text{kV}$  air and  $\pm 30\text{kV}$  contact discharge. It is assembled into a 3-pin lead-free SOT-523 package. The small size, and high ESD surge protection make DC0511S2 an ideal choice to protect cell phone, digital video interfaces, high speed data ports, and many other portable applications.

## Mechanical Characteristics

- ◆ Package: SOT-523
- ◆ Case Material: "Green" Molding Compound.
- ◆ Moisture Sensitivity: Level 3 per J-STD-020
- ◆ Terminal Connections: See Diagram Below
- ◆ Marking Information: See Below

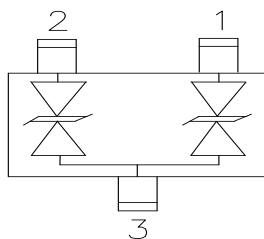

Circuit and Pin Schematic

## Features

- ◆ Low capacitance: 5pF typical
- ◆ Ultra low leakage: nA level
- ◆ Operating voltage: 5V
- ◆ Low clamping voltage
- ◆ Up to 2-lines protects
- ◆ Complies with following standards:
  - IEC 61000-4-2 (ESD) immunity test
    - Air discharge:  $\pm 30\text{kV}$
    - Contact discharge:  $\pm 30\text{kV}$
  - IEC61000-4-5 (Lightning) 3.5A (8/20 $\mu\text{s}$ )
- ◆ RoHS Compliant

## Applications

- ◆ Cellular Handsets and Accessories
- ◆ Notebooks and Handhelds
- ◆ Personal Digital Assistants
- ◆ Portable Instrumentation
- ◆ Digital Cameras
- ◆ Peripherals
- ◆ Audio Players, Keypads, Side Keys, LCD

## Dimensions and Pin Configuration

## Marking Information

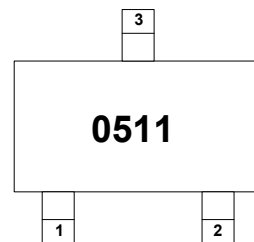

0511 = Device Marking Code

## Ordering Information

Part Number	Marking	Packaging	Reel Size
DC0511S5	0511	3000/Tape & Reel	7 inch

### **Absolute Maximum Ratings ( $T_A=25^\circ\text{C}$ unless otherwise specified)**

Parameter	Symbol	Value	Unit
Peak Pulse Power (8/20 $\mu\text{s}$ )	Ppk	40	W
ESD per IEC 61000-4-2 (Air)	VESD	$\pm 25$	kV
ESD per IEC 61000-4-2 (Contact)		$\pm 22$	
Operating Temperature Range	TJ	-55 to +125	$^\circ\text{C}$
Storage Temperature Range	Tstg	-55 to +150	$^\circ\text{C}$

### **Electrical Characteristics ( $T_A=25^\circ\text{C}$ unless otherwise specified)**

Parameter	Symbol	Min	Typ	Max	Unit	Test Condition
Reverse Working Voltage	VRWM			5	V	Pin 1 to Pin 3 or Pin 2 to Pin 3
Breakdown Voltage	VBR	6			V	IT = 1mA, Pin 1 to Pin 3 or Pin 2 to Pin 3
Reverse Leakage Current	IR			0.2	$\mu\text{A}$	VRWM = 5V, Pin 1 to Pin 3 or Pin 2 to Pin 3
Clamping Voltage	VC			8	V	I <sub>PP</sub> = 1A (8 x 20 $\mu\text{s}$ pulse), Pin 1 to Pin 3 or Pin 2 to Pin 3
Clamping Voltage	VC			12	V	I <sub>PP</sub> = 3.5A (8 x 20 $\mu\text{s}$ pulse), Pin 1 to Pin 3 or Pin 2 to Pin 3
Junction Capacitance	CJ		5		pF	VR = 0V, f = 1MHz

**Typical Performance Characteristics (TA=25°C unless otherwise Specified)**

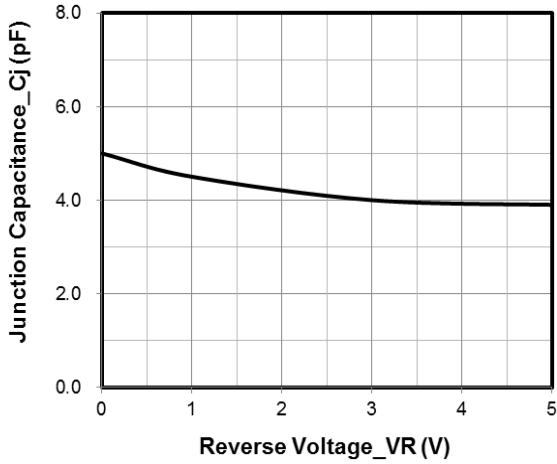

**Junction Capacitance vs. Reverse Voltage**

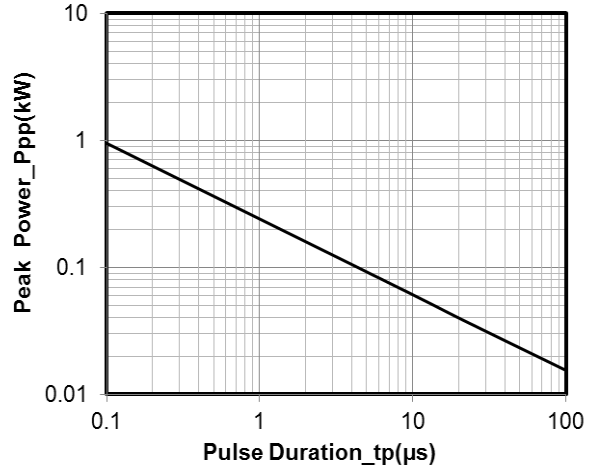

**Peak Pulse Power vs. Pulse Time**

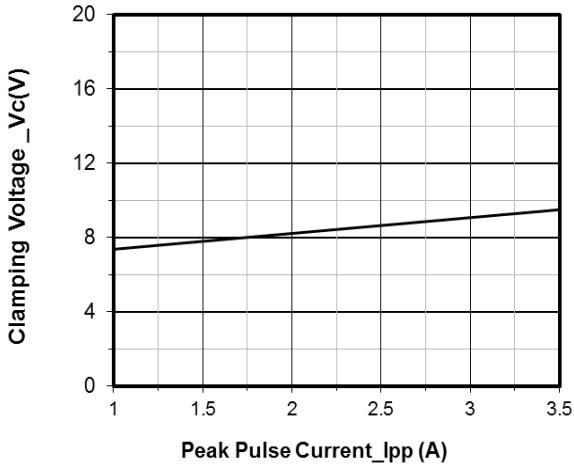

**Clamping Voltage vs. Peak Pulse Current**

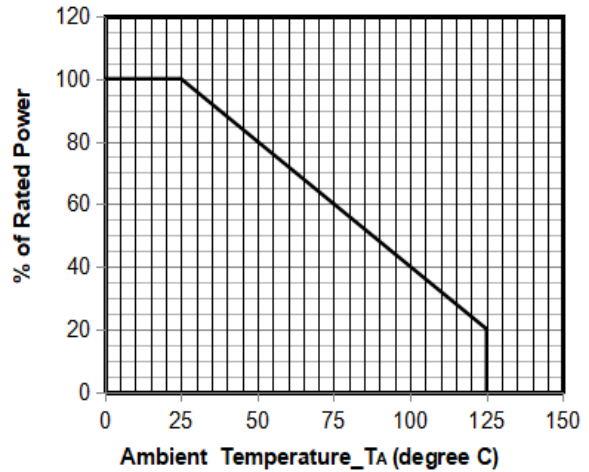

**Power Derating Curve**

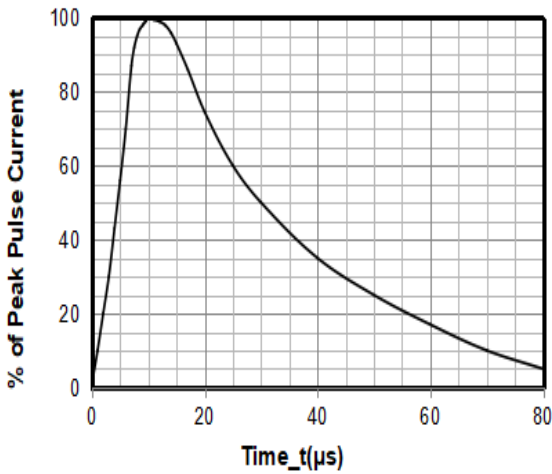

**8 X 20μs Pulse Waveform**

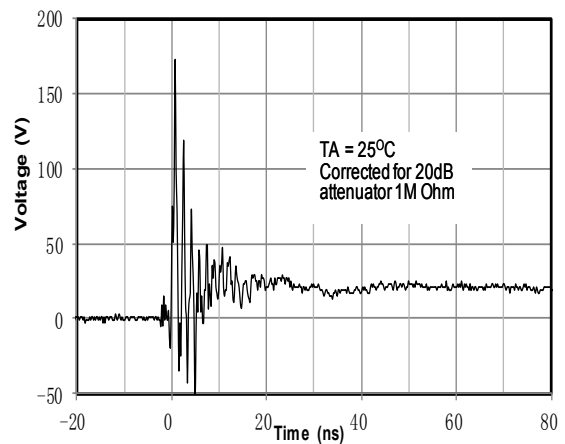

**ESD Clamping Voltage**

**8 kV Contact per IEC61000-4-2**

### SOT-523 Package Outline Drawing

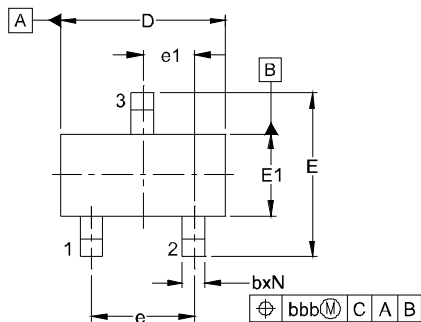

DIM	INCHES			MILLIMETERS		
	MIN	NOM	MAX	MIN	NOM	MAX
A	.023	-	.035	0.60	-	0.90
A1	.000	-	.004	0.00	-	0.10
A2	.023	.030	.031	0.60	0.75	0.80
B	.005	-	.012	0.15	-	0.30
C	.003	-	.008	0.10	-	0.20
D	.059	.063	.067	1.50	1.60	1.70
E	.057	.063	.069	1.45	1.60	1.75
E1	.029	.031	.033	0.75	0.80	0.85
e	.039 BSC			1.00 BSC		
e1	.020 BSC			0.50 BSC		
L	(.009)			(0.22)		
N	3			3		
$\theta$	0°	-	8°	0°	-	8°
aaa	.004			0.10		
bbb	.008			0.20		

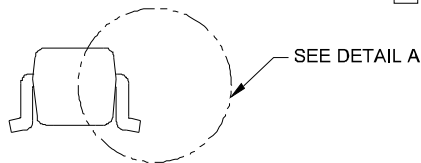
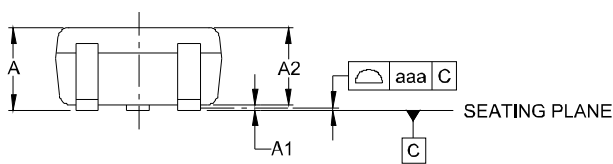

SIDE VIEW

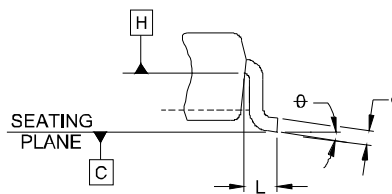

DETAIL A

### Suggested Land Pattern

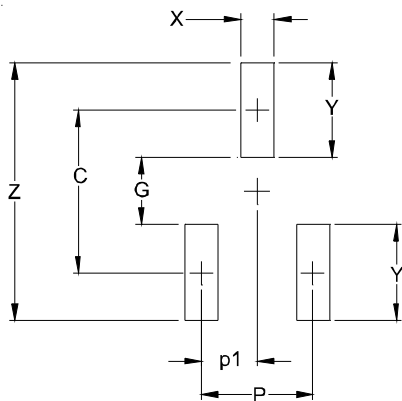

SYM	DIMENSIONS	
	INCHES	MILLIMETERS
C	(.055)	(1.40)
P	.039	1.00
P1	.020	0.50
G	.024	0.60
X	.016	0.40
Y	.031	0.80
Z	.087	2.20

### Contact Information

Changzhou D-first Electronics CO.,Ltd.

www.first-electronic.com

Email: xhf@first-electronic.cn

Phone: +86 (0519) 8817 1671